

JH Solar

It is difficult to promote industrial energy storage



Overview

Industrial energy storage is essential for manufacturers. This article reviews various systems, such as lithium-ion batteries, flywheels, and thermal energy storage, highlighting their benefits and challenges with real-world case studies. It also examines future trends indicating the transformative.

Industrial energy storage is essential for manufacturers. This article reviews various systems, such as lithium-ion batteries, flywheels, and thermal energy storage, highlighting their benefits and challenges with real-world case studies. It also examines future trends indicating the transformative.

Recent global upheavals and uncertainties are putting increasing strain on businesses around the world prompting governments to look closely at energy efficiency as a means to promote industrial competitiveness and the resilience of businesses. At the COP28 climate change conference in 2023, nearly

The increasing global energy demand and the transition toward sustainable energy systems have highlighted the importance of energy storage technologies by ensuring efficiency, reliability, and decarbonization. This study reviews chemical and thermal energy storage technologies, focusing on how they. What are the challenges of energy storage?

The ability to integrate the capabilities of storage technologies to the specific requirements of each industrial process is one of the main challenges of energy storage, with the selection of the optimal storage system depending on the needs of the industrial process.

What are the challenges in hydrogen storage & distribution?

One of the main challenges in hydrogen storage and distribution is the inherent trade-off between its high gravimetric energy density and low volumetric energy density. Although hydrogen contains more energy per kilogram than most fuels, its energy per unit volume is significantly lower under standard conditions.

How effective is rock thermal storage?

However, the effectiveness of rock thermal storage depends on factors such as thermal conductivity, porosity, and heat transfer efficiency, influencing system scalability and energy dispatch capabilities . Liquid Air Energy Storage (LAES) is a cryogenic storage solution that uses the liquefaction of air at -196°C to store energy .

How can industrial facilities reduce energy and demand costs?

The potential of industrial facilities to reduce energy and demand costs through these technologies is one of the industry's advantages. This creates a balance between production and consumption while also improving the reliability and financial performance of the electrical grid .

Why do we need thermal energy storage systems?

Thermal energy storage systems reveal even greater diversity in terms of temperature range, material costs, and industrial compatibility.

Why do we need energy storage systems?

Decarbonizing the energy sector is essential, with the Energy Storage Systems (ESS) being of great importance in the achievement of this goal. These technologies enhance the integration of renewable sources, improving supply stability and efficiency, thus facilitating the transition to a more sustainable energy model .

It is difficult to promote industrial energy storage

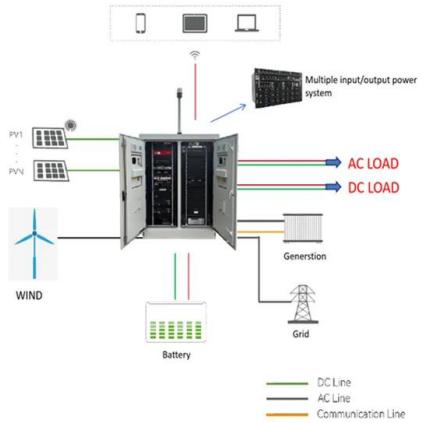

Industrial Energy Storage Review

The industrial sector's primary energy requirement is thermal energy; therefore, thermal storage could be an integral technology that can reduce carbon emissions, help the industrial sector ...

Comprehensive review of energy storage systems technologies, ...

Energy storage is one of the hot points of research in electrical power engineering as it is essential in power systems. It can improve power system stability, shorten energy ...



Commercial Energy Storage Guide: Types and ...

Commercial energy storage comes with a lot of benefits for commercial and industrial customers. Learn the different types that are available, costs, and more.

Energy Storage Systems for Commercial and ...

Explore the benefits of industrial and commercial energy storage solutions in this article. Discover how advanced business energy storage systems

can enhance energy efficiency, reduce costs, and ...



Attention Towards Energy Infrastructures: Challenges and Solutions

The energy infrastructure sector faces numerous challenges, including integrating renewable energy, digitizing energy systems, energy storage, microgrids and community ...

How Industrial Energy Storage Systems Support Grid Stability

1. Industrial energy storage systems play a critical role in enhancing grid stability by effectively managing supply and demand fluctuations, integrating renewable energy ...

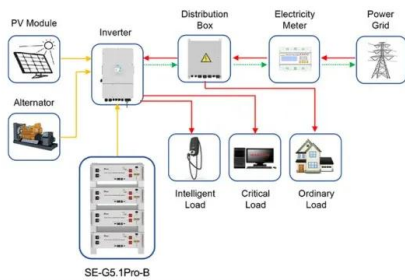
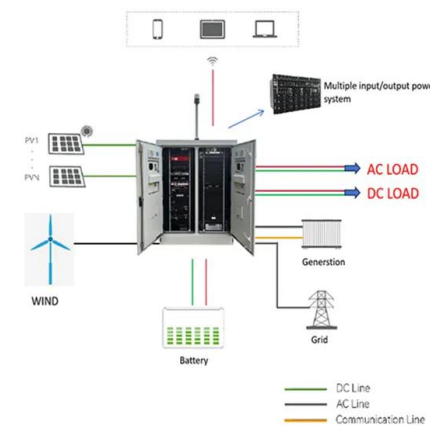

Application scenarios of energy storage battery products

Breaking barriers: Challenges to implementing ...

Discover the challenges and opportunities in implementing innovative energy storage solutions. Explore barriers like technology gaps, economic hurdles, regulatory complexities, and societal acceptance, along ...

Energy Storage: From Fundamental Principles to ...

The increasing global energy demand and the transition toward sustainable energy systems have highlighted the importance of energy storage technologies by ensuring efficiency, reliability, and ...



Energy storage: challenges and opportunities

Discover challenges & opportunities in energy storage. Expert analysis & strategies to optimise energy management & drive sustainability.

Understanding energy storage systems for ...

Supplying Power During Excess Demand Energy storage systems can support excess energy demands for commercial and industrial applications when the power requirement increases. This situation arises ...



**LPR Series 19[®]
 Rack Mounted**



Why is energy storage difficult in my country? , NenPower

Energy storage presents significant challenges in your country due to several key factors: 1. Inadequate infrastructure impedes efficient energy storage solutions, 2. Economic ...

Industrial Energy Storage: Powering Factories and Industries

Industrial energy storage is essential for manufacturers. This article reviews various systems, such as lithium-ion batteries, flywheels, and thermal energy storage, ...



it is difficult to promote industrial energy storage

Energy storage is the conversion of an energy source that is difficult to store, like electricity, into a form that allows the energy produced now to be utilized in the future.

Navigating challenges in large-scale renewable energy storage: ...

With the growing global concern about climate change and the transition to renewable energy sources, there has been a growing need for large-scale energy storage than ...

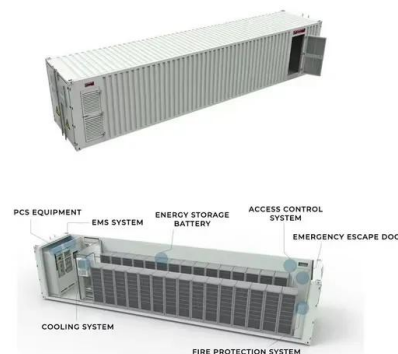

Energy Storage Systems for Commercial and Industrial Applications

Additionally, energy storage can help businesses manage their energy load, improve power quality, and ensure a reliable backup power supply in case of grid outages. For ...

Progress and prospects of energy storage technology

The development of energy storage technology (EST) has become an important guarantee for solving the volatility of renewable energy (RE) generation and promoting the ...



What are the main operational challenges of industrial energy

...

Main operational challenges of industrial energy storage systems include 1. insufficient integration with existing infrastructure, 2. high capital and maintenance costs, 3. ...

Energy Storage: From Fundamental Principles to ...

This study reviews chemical and thermal energy storage technologies, focusing on how they integrate with renewable energy sources, industrial applications, and emerging challenges.



2020 China Energy Storage Policy Review: ...

In 2020, under the direction of the National Development and Reform Commission to promote energy storage and lay a solid foundation for industrial development, the Ministry of Education, the ...

Industrial Energy Storage: The Key to Unlocking Efficiency and

...

Advanced energy storage solutions are revolutionizing industrial applications, offering unprecedented opportunities for energy efficiency, cost reduction, and sustainability. ...



What are the regulatory challenges facing industrial energy storage

Industrial energy storage systems have emerged as critical components in the transition toward sustainable energy sources and enhancing grid reliability. However, the ...

Energy Storage Industry Trends: C& I Energy Storage Market ...

In the future, GSL Energy will continue to focus on industrial and commercial energy storage solutions, promote global energy transformation, and help enterprises realize ...



Why Is Industrial Energy Storage Important for Industrial ...

The industrial sector is one of the largest consumers of energy globally, accounting for approximately 37% of total energy use according to the International Energy Agency (IEA). ...

Demands and challenges of energy storage ...

Emphasising the pivotal role of large-scale energy storage technologies, the study provides a comprehensive overview, comparison, and evaluation of emerging energy storage solutions, such as lithium-ion ...



Energy storage -- a key technology for global energy sustainability

This calls for the practical application of energy-storage systems. An evaluation is made of the prospects of the candidate storage technologies -- pumped-hydro, flywheels, ...

Industrial Energy Storage: Enhancing the reliability of energy supply

Varied industrial energy storage systems exhibit a diverse array of energy storage and output capabilities. The table below presents a comparison of the efficiency rates ...



Regulating the structure of hard carbon derived from industrial ...

However, the low carbonization yields of biomass-derived hard carbons and the waste produced during industrial production processes contribute to the high production cost of these hard ...

Industrial energy organizations: cost sharing, grid effect, and ...

This study investigated the economic and operational viability of energy storage investments in industrial settings, comparing independent optimization with a cooperative ...



How to promote industrial and commercial energy storage ...

Commercial and industrial energy storage refers to systems designed to capture and store energy in commercial and industrial environments, enabling businesses to manage orce in ...

Current status, problems and promotion strategies of AI ...

However, there is still a lack of scientific guidance on how to promote the application of AI technology in industrial energy management. To date, no relevant research ...

- LiFePO₄
- Wide temp: -20°C to 55°C
- Easy to expand
- Floor mount&wall mount
- Intelligent BMS
- Cycle Life:≥6000
- Warranty :10 years



A study on the energy storage scenarios design and the business ...

Finally, taking an actual big data industrial park as an example, the economic viability of energy storage configuration schemes under two scenarios was discussed, and an ...

Overcoming All Barriers To Industrial Electrification

A range of policy solutions can promote industrial electrification. A more detailed breakout shows how each policy can help address the main barriers to industrial electrification.



Industrial Energy Storage Review

This report examines the different types of energy storage most relevant for industrial plants; the applications of energy storage for the industrial sector; the market, business, regulatory, and ...

Contact Us

For catalog requests, pricing, or partnerships, please visit:
<https://www.apartamenty-teneryfa.com.pl>